

UH2008C-34 UH2011C-34 UH2013C-34

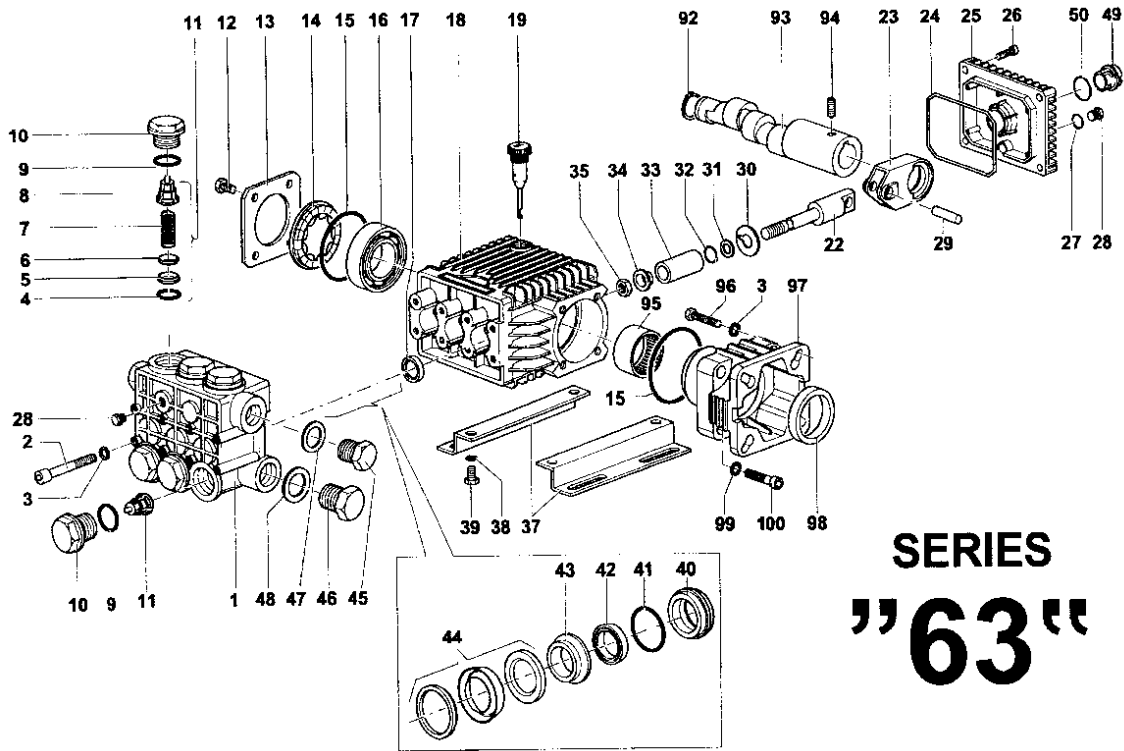

POS	REF	DESCRIPTION	KIT NO	QTY
1	63.1200.41	MANIFOLD Ø 15		1
2	99.3192.00	SCREW M8x65		8
3	96.7014.00	WASHER Ø 8		8
4	90.3841.00	O,RING 17,13x2,62	KIT123	6
5	36.2003.66	VALVE SEAT	KIT123	6
6	36.2001.76	VALVE	KIT123	6
7	94.7376.00	SPRING Ø 9,4x14,8	KIT123	6
8	36.2025.51	VALVE GUIDE	KIT123	6
9	90.3847.00	O'RING Ø 20,24x2,62	KIT124	6
10	98.2226.00	CAP M24x1,5x17	KIT124	6
11	36.7115.01	VALVE UNIT	KIT123	6
12	99.1807.00	SCREW M 6x10		4
13	50.1500.74	CRANCASE COVER		1
14	44.2118.01	DISTANCE INDICATOR		1
15	90.4097.00	O'RING Ø 55,56x3,53		2
16	91.8328.00	BALL BEARING		1
17	90.1595.00	OIL SEAL Ø 18x26x6	KIT159	3
18	63.0100.22	CRANKCASE		1
19	98.2103.00	OIL DIPSTICK		1
22	63.0500.66	PISTON GUIDE		3
23	63.0300.22	CONNECTING ROD		3
24	90.3920.00	O'RING Ø 101,27x2,62		1
25	63.1600.22	CRANKCASE COVER		1
26	99.1837.00	SCREW M6x14		4
27	90.3585.00	O'RING Ø		1
28	98.2041.00	CAP 1/4x9		2
29	97.7335.00	PISTON PIN Ø 9x27,5		3
30	96.7075.00	W ASHER Ø 9x25x0,5		3
31	90.5022.00	ANTI-EXTRUTION RING		3
32	90.3573.00	O'RING 5,28x1,78		3
33	52.0400.09	PISTON Ø 15		3

POS	REF	DESCRIPTION	KIT NO	QTY
34	44.2115.70	WASHER Ø 8		3
35	92.2216.00	NUT Ø M8		3
37	50.2000.74	FOOT- OPTIONAL		2
38	96.7016.00	WASHER Ø 8 - OPTIONAL		4
39	99.3037.00	SCREW M8x16 -OPTIONAL		4
40	63.0800.70	PACKING RETAINER Ø 15	KIT162-166	3
41	90.3608.00	O'RING Ø 28,3x1,78	KIT166	3
42	90.2608.00	LOW PRESSURE SEAL Ø 15	KIT160-166	3
43	63.2160.70	INTERMEDIATE RING Ø 15	KIT164-166	3
44	90.2612.00	HIGH PRESSURE SEAL Ø 15	KIT160-166	3
45	98.2100.00	CAP 3/8x13		1
46	98.2176.00	CAP 1/2x10		1
47	96.7380.00	WASHER Ø17,5x23x1,5		1
48	96.7514.00	WASHER Ø 21,5x27x1,5		1
49	63.2100.51	OIL LEVEL INDICATOR		1
50	90.4051.00	O-RING Ø26,58x3,53		1
92	90.0635.00	CIPCLIP		1
93	63.0262.65	CRANKSHAFT UH2008		1
93	63.0264.65	CRANKSHAFT UH2011		1
93	63.0266.65	CRANKSHAFT UH2013		1
94	99.1790.00	SCREW M6X6 UNI5929 CL. 12.9		1
95	91.8568.00	NEEDLE ROLLER BEARING		1
96	99.2730.00	SCREW 5/16X3/4"X24 UNF		4
97	10.0617.22	FLANGE FOR ENGINE		1
98	90.1687.00	OIL SEAL Ø45X60X8		1
99	96.6938.00	WASHER Ø6		4
100	99.1912.00	SCREW M6X30 UNI 5931		4

SERVICE REPAIR KITS AVAILABLE:

KIT NO	KIT 124	KIT 159	KIT 123	Ø15	KIT NO	KIT 160	KIT 162	KIT 164	KIT 166
POSITIONS INCLUDED	9-10	17	4-5-6 7-8(11)	UH2008 UH2011 UH2013	POSITIONS INCLUDED	42-44	40	43	40-41-42 43-44
N. PCS	6	3	6		No pcs.	3	3	3	1