

Circuit diagramme

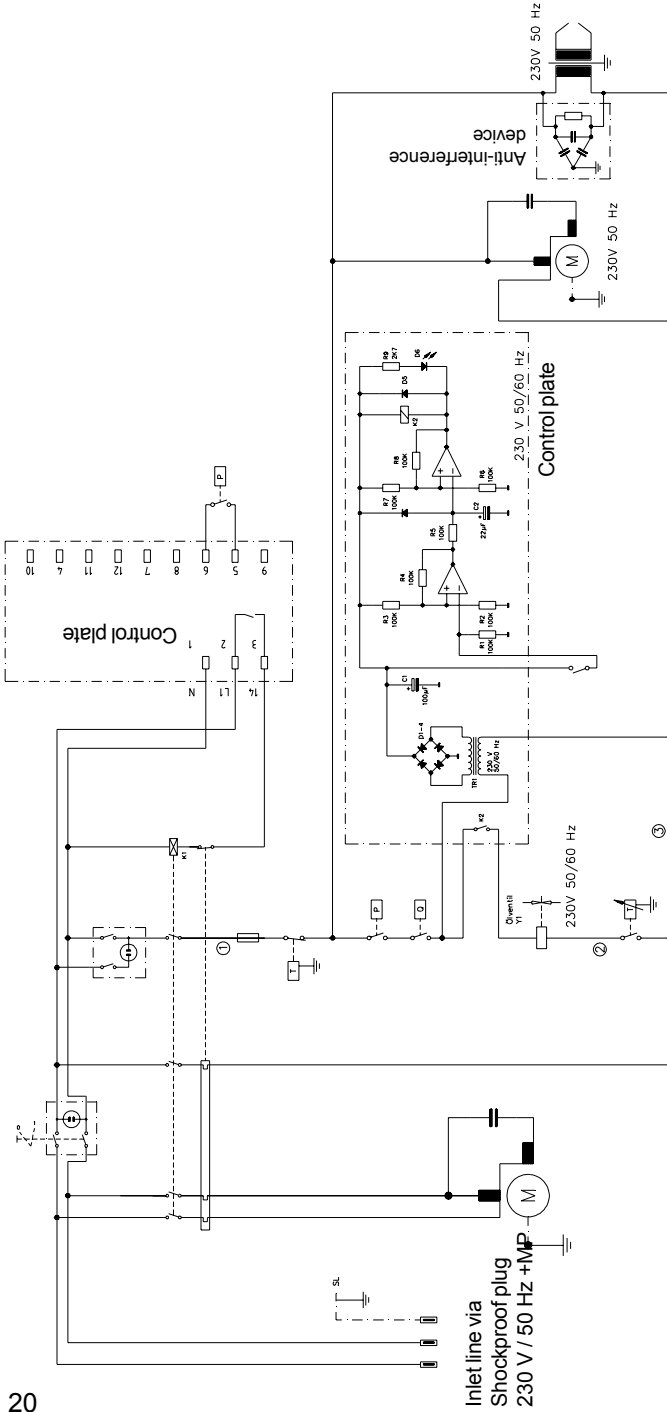

- | | | | |
|----|----------------------------|----|------------------------------|
| A1 | Ignition transformer | S1 | Excess temperature trigger |
| B1 | Thermostat | S2 | Differential pressure switch |
| F1 | Fuse 3.15 timeIag | S3 | Press switch burner release |
| K3 | Motor contactor | S4 | Float switch (Fuel) |
| M1 | Motor, HP pump | Y1 | Fuel valve |
| M2 | Combustion motor | | |
| Q1 | Master switch | | |
| | 14,5 A overload protection | | |

Cockpit terminal plan

